

EPS 6000 *series 800*

800kVA/720kW, 750kVA/712kW

Where Power and Reliability Converge

Advanced Features

- ▶ 0.9/0.95 output Power Factor
- ▶ Space saving footprint
- ▶ High energy efficiency
- ▶ Large graphical user interface*
- ▶ 12 pulse rectifier
- ▶ Ultra low kVAR data grade input filter
- ▶ Excellent generator compatibility
- ▶ Non-linear load optimized
- ▶ IGBT PWM inverter with Digital Power Quality logic
- ▶ < 4% max. output THD
- ▶ Advanced battery management system
- ▶ Critical Bus Synchronization
- ▶ 100% step load enabled
- ▶ Integrated isolation transformer
- ▶ Modular construction
- ▶ Multi-port serial communications interface
- ▶ Easy integration with most monitoring systems
* optional



800 series

The EPS 6000 series 800 specifications read like a list of ideal answers to today's critical power user requirements. Featuring a true IGBT PWM inverter that feeds 720 kW per UPS of computer grade power (<4% THD) to your critical loads, the **series 800** meets all your high power requirements in a compact footprint.

Series 800 users will enjoy substantial cost savings as MGE's Digital Power Quality logic keeps the inverter efficiency high even when the UPS is lightly loaded. On the input side, a 12 pulse rectifier combined with MGE's data grade input filter boasts very low THD, low kVAR and no leading power factor, making the **series 800** ideal for generators.

Sharing the same bullet proof construction as the EPS 6000, the **series 800** bounces back from most foreseeable user mishaps that prove fatal to other UPSs. The **series 800** also features the industry's best graphical user interface, full front accessibility, multi-port open protocol communication interface, and EPS 6000's history of reliability making it the best choice for high availability critical power systems.

M G E
UPS SYSTEMS

MGE series 800 ~ Where Power & Reliability Converge

Proven Reliability

The EPS 6000 series 800 uses identical control components found in MGE's EPS 6000 UPS which boasts an outstanding track record of reliability in thousands of installations since 1992. Designed without compromise, the series 800 is simply an optimized version of the EPS6000 incorporating refinements suggested by engineers and customers. **Based on favorable results from rigorous testing the series 800 has already been selected for use in many of the world's largest data centers.**

High Energy Efficiency for True Cost Savings

The EPS 6000 series 800 maintains very high-energy efficiency even when lightly loaded, where most UPSs operate. This is a major cost savings advantage as many other UPSs drop their efficiency as the load drops. MGE's stable efficiency is due to its *Digital Power Quality Logic* system that constantly optimizes the switching frequency for the load level and load profile, minimizing switching losses. **The result is operating cost savings that can equal the value of the UPS in as little as three to five years.**

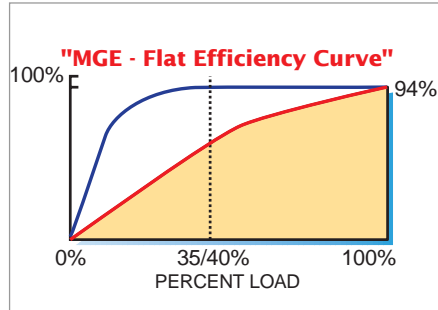

EPS 6000 efficiency remains stable even when the UPS is lightly loaded, offering a large efficiency advantage over other UPS manufacturers.

Annual Cost Savings of a 1-3% efficiency advantage

Efficiency Advantage			
UPS Load	1%	2%	3%
1,000 kW	\$68,000	\$136,000	\$204,000
800 kW	\$54,000	\$108,000	\$163,000
600 kW	\$41,000	\$81,000	\$122,000

Savings Per Year

*Calculated as future value at 7% cost of capital compounded monthly at \$0.1 kWh plus air conditioning costs. Savings will vary with energy rates.

Digital Power Quality Logic & IGBT Inverter Technology

While many UPS manufacturers use IGBT (Insulated Gate Bipolar Transistors) inverters to simplify inverter design and increase reliability, MGE is the first manufacturer to build a UPS topology that also takes advantage of the clean switching characteristics of IGBTs. This is achieved by generating the output waveform using true high frequency digital pulses (Pulse Width Modulation). Every pulse of the output waveform is precisely controlled by MGE's unique Digital Power Quality (DPQ) management system. The DPQ system compares the output waveform to a computer generated reference sine wave. A feedback circuit then actively corrects any waveform imperfections.

PWM and Comparator circuit

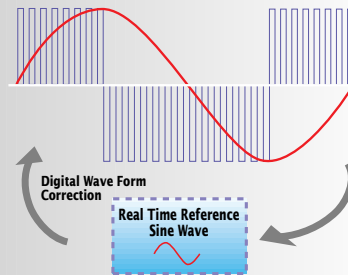

MGE's exclusive Digital Power Quality precisely regulates voltage for distortion free power.

100% Step Load Change

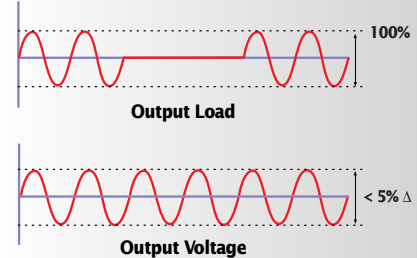

Even when exposed to a 100% step load voltage transients are limited to under 5%.

The result is a practically distortion free (<4% THD) output when powering 100% non-linear loads and very low voltage transients (<5%) even when faced with 100% step loads.

Space Saving Footprint/No Rear Access: Fitting into a space as little as 20 inches wide, the series 800 has one of the highest power densities of any UPS. The standard series 800 includes an input isolation transformer and input filter in the UPS cabinet eliminating the need for bulky auxiliary cabinets. Matching maintenance bypass cabinets are compact yet functional adding only 24 inches to the width. All series 800 components including the transformers are truly front accessible with no rear or side access requirements, saving even more footprint.

- ▶ 23 kW / square foot high power density
- ▶ 120" wide including input isolation transformer & filter (multi-module / 135" single module w/ bypass)
- ▶ No rear or side access required
- ▶ Easy front thermal scanning with terminal viewing ports
- ▶ Modular construction

720 kW/33ft²
(multi-module with input isolation and filter)



Proven Data Center Power Protection

Generator Friendly Technology

By combining a low distortion 12 pulse rectifier with a passive inductive filter, the *series 800* limits input distortion to around 5% while minimizing kVARs to a negligible level. Even when lightly loaded UPS input power factor is not leading. Together, these conditions are ideal for generators and limit over sizing requirements.



Advantage MGE

MGE Input Filters Feature:

- ▶ Low Input Distortion
- ▶ Very Low kVAR
- ▶ No Leading Power Factor
- ▶ No mechanical switching of filters

MGE UPS SYSTEMS The power behind Internet Data Centers

Advanced Graphical User Interface:

An optional large LCD **touch screen** complements the *series 800* controls to provided features including active mimic diagrams, alarm / event logs and more. The simplicity of the display helps operators of all knowledge levels understand UPS status and operation at a glance, limiting operator errors.



Rapid, Expert Service Means

Maximum Uptime: MGE's **120 factory trained Field Engineers** are strategically located throughout North America ensuring a rapid response with 7x24 service.

Computer Aided Diagnostics assist the Field Engineers detecting issues before they have a chance to compromise UPS performance.



Communications and Software Solutions

The *EPS 6000* interfaces easily with most building management systems using an open ModBus based protocol or a detailed set of dry contacts. A full range of communications and software solutions is available to meet your specific requirements.

- ▶ **Dual RS232 / RS485 serial ports** - (JBUS / ModBUS) - detailed UPS status information
- ▶ **Dry contacts** - all critical UPS status points
- ▶ **Teleservice** - auto alert feature notifying MGE and the customer of alarm conditions / remote status verification
- ▶ **SNMP Network Management Card** - obtain UPS status over networks
- ▶ **Solution-Pac** - network power management software for automatic server shutdown
- ▶ **Monitor-Pac** - advanced UPS system monitoring software



Monitor-Pac UPS monitoring software for Facility Managers and Engineers

Fault Tolerant Circuitry

Robust enough to withstand the worst possible circumstances.

EPS 6000 UPSs are equipped with unique fault tolerant circuitry. Even when exposed to dead shorts on the output that prove fatal to other UPSs, the *EPS 6000* will recover without sustaining damage or clearing fuses, and immediately continue to protect the critical load. Because changes on the load side of the UPS are increasingly common, output fault tolerant circuitry is the best protection against user-induced faults and load side equipment faults.

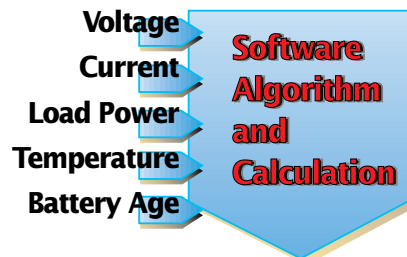

- ▶ Time remaining
- ▶ Temp-compensated charging
- ▶ End of life predictions
- ▶ Discharge curve comparisons

Advanced Battery Management:

Battery banks represent a major investment in large UPS systems. Proper monitoring and battery management is essential for reliable UPS performance and battery bank longevity. MGE's Advanced Battery Management system includes features like temperature compensated charging and active discharge curve comparisons to:

- ▶ **maximize battery life** by ensuring proper float voltages
- ▶ **provide accurate time remaining** information by monitoring all parameters related to capacity
- ▶ **alert users to irregularities** before they affect the critical load by comparing the manufacturers data with actual battery discharge data.

Single Module Schematic

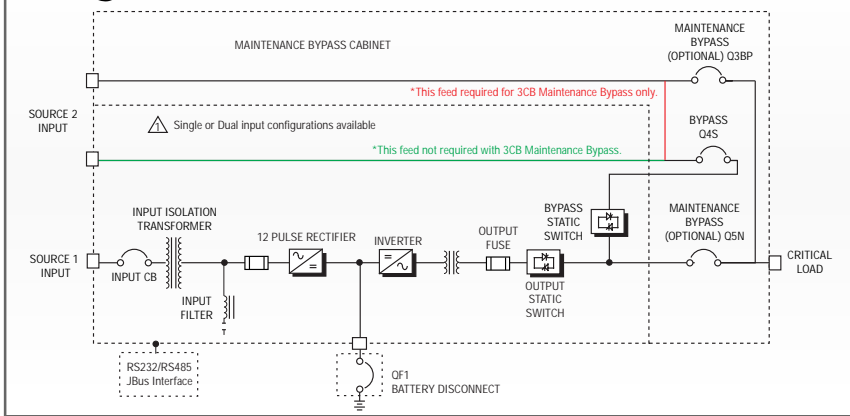

Multi-Module Schematic

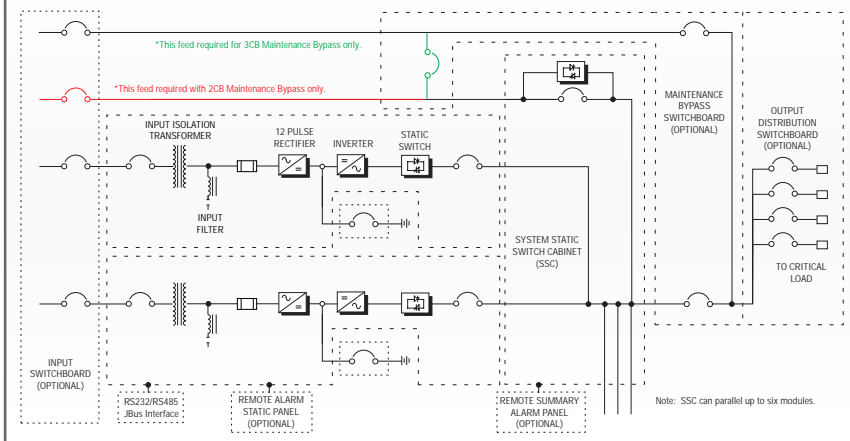

Technical Specifications

	800kVA/720kW	750kVA/712kW
Input/Output Voltage ¹ (V)	480/480	480/480
Nominal Input (A)	1061	987
Input CB (kAIC)	100	100
Frame Size/Trip (A)	2,000/1,600	2,000/1,600
Nominal Bypass Current (A)	960	900
Maint. Bypass CB ² (KAIC)	65	65
Trip (A)	1,200	1,200
UPS Output Isolation CB ² (KAIC)	65	65
Frame Size/Trip (A)	1,200/1,200	1,200/1,200
UPS Output Current (A)	960	902
10 min OL Current (A)	1,152	1,127
DC Breaker		
Frame Size/Trip (A)	2,000/2,000	2,000/2,000
Core System Efficiency (100%-25% load)	94.5%	94.5%
UPS Efficiency (with isolation transformer)		
100% Load	93%	93%
50% Load	94%	94%
Core Unit Full Load Heat Rejection (BTUs)	190,000	170,000
Multi Module Width ³ (39"Dx82"H)	121"	121"
Single Module Width ³ -Top Entry (39"Dx82"H)	135"	135"
Maintenance Bypass for single module	22"	22"
Battery Disconnect Width (28"Dx90"H)	36"	36"
Max. Shipping Split Width	61"	61"
UPS Cabinet Weight ⁴ (lbs)	13,000	12,900

¹ 600/600 V models also available ² add to single module width ³ dimensions include isolation transformer & input filter ⁴ exact weight subject to module configuration



Standard Features

- ▶ Input isolation transformer
- ▶ Low kVAR input filter
- ▶ IGBT PWM inverter w/Digital Power Quality logic
- ▶ 12 pulse rectifier
- ▶ Serial and dry contact communications interface
- ▶ Computer aided diagnostics
- ▶ Advanced battery management
- ▶ No rear access
- ▶ Redundant fan assemblies

AC Input

- ▶ Input Voltage 480/600 VAC (3ph, 3W + G) +/- 15%
- ▶ Frequency (Hz) 60 Hz +/- 10%
- ▶ Power Factor 0.9 lagging @ nominal load (never leading)
- ▶ Input Current Distortion 5-7% max. THD

AC Output

- ▶ Power Factor 0.9 (800 kVA) / 0.95 (750 kVA)
- ▶ Voltage 480/600 VAC (3ph, 3/4W, N, + G)
- ▶ Frequency 60 Hz (selectable 1-5%) +/- 0.1% free running
- ▶ Voltage Regulation +/- 0.5% steady state (< +/- 5% 100% step load)
- ▶ Voltage Distortion 4% max for non-linear loads w/crest factor of 3.5
- ▶ Inverter Overload 125% for 10 minutes, 135% 150% for 1 minute, 165% if bypass not available
- ▶ Bypass Overload 1000% for 1 second
- ▶ Unbalanced Load Up to 100% 120 +/- 3%, max. angle displacement, +/- 2.5%, max. voltage deviation

Bypass Input

- ▶ Voltage +/- 10% UPS output voltage (3ph, 3W, + G)
- ▶ Frequency 60Hz (+/- 0.25 Hz up to 1Hz)

DC Ratings

- ▶ Nominal/Float V 480/545 VDC
- ▶ DC max. Current 2000 A

Environmental

- ▶ Operating Temperature 0°C to 40°C
- ▶ Audible Noise 75-78 dB @ 3'
- ▶ Humidity 0-95% non-condensing

Standards

- ▶ UL 1778
- ▶ IEEE 587/ANSI C62.41 (surge withstand)

Options

- ▶ Advanced Graphical User Interface
- ▶ Battery Disconnect
- ▶ Maintenance Bypass



MGE UPS SYSTEMS

USA (headquarters)
1660 Scenic Avenue
Costa Mesa, CA 92626
tel (800) 523-0142
(714) 557-1636
fax (714) 557-9788

CANADA
#9, 2798 Thamesgate Dr.
Mississauga, ON L4T 4E8
tel (905) 672-0990
(877) 672-0990
fax (905) 672-7667

ARGENTINA
Thames 91
1609 San Isidro
Prov de Buenos Aires
tel (54) 11-4766-8777
fax (54) 11-4766-6008

BRAZIL
Avenida Guido
Caloi 1985 (GALPAO 23)
Guarapiranga
Sao Paulo - SP, CEP 05802
tel (55) 11-5891-2274
fax (55) 11-5890-3353

MEXICO
Ave. Congreso de la
Union
#524 Colonia Santa Anita
Mexico D.F 08300
tel 525 538 9687
fax 525 530 7625

www.mgeups.com
info@mgeups.com

EPS 8kVA 102
Effective: December 2001